

# PRODUCT CATALOGUE



*eSupplier*  
Pittemstraat 88A, 8760 Meulebeke BE  
+32(0)493.50.51.05 | Tibo De Soete  
+32(0)492.58.11.83 | Micha Denys  
info@esupplier.be - www.esupplier.be

*Photos are indicative and may differ from actual vehicle.  
Subject to terms and conditions at www.esupplier.be*



## Low Speed Electric Golfcarts, Utility Vehicles, 4x4 & Shuttles



e-Supplier offers a full range of electric vehicles, both street-legal for driving on public roads and non-street-legal for driving on private terrains. We offer a high-end full option line as well as more budget options in order to offer the best solutions for all types of application and customers' requirements. Our vehicles can be used for both light application (golf, hotels & resorts, ...) as for more demanding applications (campings, rental, agro, logistics, construction, ...).

## Cargo-Truck & Specials



With its full electric drive, compact dimensions and impressive driving range our eFFort Cargo-Truck is a perfect solution for urban logistics and available in many different lay-outs with multiple cargo option. The touchscreen with infotainment, an integrated heating and air-conditioning system and ultra comfortable ergonomic seating all contribute to a great driving experience. Be ready for the future and get to know all the features and options.

## eFFort LiFePO4 Lithium Batteries



Based on our long experience of battery design and production of lithium batteries for producers of smaller applications like ebikes, drones, electric wheelchairs, AGV's, ... we decided to build a range of 24V and 48V batteries for golfcarts, aerial work platforms, scissor lifts, industrial cleaning machines, boats, utility vehicles, etc. Our high quality eFFort batteries are fully in line with the EU directives and come with a 5-years warranty. Our range consists of top class components and includes some very interesting technical features. Our eFFort. Your equipment. Discover our range!

## Crown Lead Acid Batteries



e-Supplier is a long-time distribution partner for Crown Battery. This USA based producer offers a full line of deepcycle batteries for recreational EV, access work platforms, scissor lifts and cleaning machines. They are tough, tested and proven to deliver years of reliable, rechargeable service and performance. Pure Power. Get to know our full range of battery models.

## Parts and Accessories



Selling one electric vehicle is not difficult, but selling many vehicles comes with a responsibility! Our customers rely on us and our distributors for a good service-after-sales. That is why we put of lot of time in training our dealers to understand each aspect of our vehicles. Our large stock of parts and accessories add up to our customer-oriented market view and allows for quick assistance.

## Used Vehicles



We always have available from stock a nice range of 2<sup>nd</sup> hand vehicles, usually from top brands like Clubcar and EZGO. We offer these in an "as is" configuration or fully technically and/or visually inspected. Additional options, like a small cargo box or a rear seat for two extra passengers, are available too!

## OEM Battery Production



For many years we have designed and produced lithium batteries on behalf of producers of cashier systems, VR applications, alarm systems, AGV's, golfcarts, etc. These are custom-made battery packs that are designed and tested with the equipment manufacturer until the perfect battery is ready. We apply for all required certificates and – according to the customer's forecast – organize the production. The batteries are stocked in Belgium and shipped to the customer, depending on his specific requirements. Interested in this high-levelled service for your equipment?

# VEHICLES - STREET LEGAL



Public roads



Municipalities



Tourism



Last mile delivery



Vineyard



Event renting



Agriculture



PC2SL

- 2-seater
- 6kW engine
- EU Homologation L7
- 100% electric
- 50 km autonomy\*
- Full option
- Battery not included



PC4SL

- 4-seater
- 6kW engine (10kW optional)
- EU Homologation L7
- 100% electric
- 50 km autonomy\*
- Off-road / lifted version (optional)
- Full option
- Battery not included



PCWSL

- 2-seater utility
- 6kW engine (10kW optional)
- EU Homologation L7
- 100% electric
- 50 km autonomy\*
- Off-road / lifted version (optional)
- Open Cargo: 180x130x40
- Full option
- Battery not included

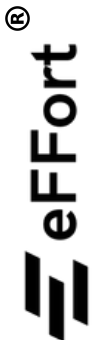

eS-2SL

- 2-seater
- 4kW engine
- EU Homologation L6
- 100% electric
- 50 km autonomy\*
- Full option
- Battery included (Lithium eFFort)



eS-4SL

- 4-seater
- 6kW engine
- EU Homologation L7
- 100% electric
- 50 km autonomy\*
- Full option
- Battery included (Lithium eFFort)



eS-WSL

- 2-seater utility
- 6kW engine
- EU Homologation L7
- 100% electric
- 50 km autonomy\*
- Full option
- Open Cargo: 100x110x27
- Battery included (Lithium eFFort)



### eFFort eS-2SL (Street Legal)

Category	L6eCP
Curb weight	403 kg
Max total mass	513 kg
Max speed	30 km/h
Range +/-	50 km
Max gradient	30%
Dimensions	2380x1200x1850 mm
Wheelbase	1640 mm
Battery	LiFePO4 (Lithium) 48V 160Ah
Charge unit	25A
Engine	6.3kW
Controller	Curtis
Optional	Open Alu Box 700x1100x275 mm Rear Seat with extended roof

### Pilotcar PC-2SL (Street Legal)

Category	L7eCP	Category	L7eCP
Curb weight	(LA)637 - (LIT) 527 kg	Curb weight	(LA)700 - (LIT) 590 kg
Total load cap	292 kg	Total load cap	600 kg
Max speed	40 km/h	Max speed	50 km/h
Range +/-	50 km	Range +/-	50 km
Max gradient	20%	Max gradient	20%
Dimensions	2460x1220x1965 mm	Dimensions	3350x1220x1965 mm
Wheelbase	1646 mm	Wheelbase	2460 mm
Battery	No Battery incl.	Battery	No Battery incl.
Charge unit	17A	Charge unit	17A
Engine	6kW	Engine	6kW
Controller	Curtis	Controller	Curtis
Optional	Plastic cargobox Open Alu Box 1000x1100x400 mm Rear Seat with extended roof Lead acid 48V 165Ah or 220Ah LiFePO4 (Lithium) 48V 106Ah or 48V 173Ah	Optional	Plastic cargobox Open Alu Box 1000x1100x400 mm Rear Seat with extended roof Lead acid 48V 165Ah or 220Ah LiFePO4 (Lithium) 48V 106Ah or 48V 173Ah 10kW motor Off-Road Package

### eFFort eS-4SL (Street Legal)

Category	L7eCP
Curb weight	504 kg
Max total mass	779 kg
Max speed	40 km/h
Range +/-	50 km
Max gradient	25%
Dimensions	3180x1200x1850 mm
Wheelbase	2430 mm
Battery	LiFePO4 (Lithium) 48V 160Ah
Charge unit	25A
Engine	6.3kW
Controller	Curtis
Optional	Open Alu Box 700x1100x275 mm Rear Seat with extended roof

### Pilotcar PC-4SL (Street Legal)

Category	L7eCP	Category	L7eCP
Curb weight	(LA)700 - (LIT) 590 kg	Curb weight	(LA)700 - (LIT) 590 kg
Total load cap	600 kg	Total load cap	600 kg
Max speed	50 km/h	Max speed	50 km/h
Range +/-	50 km	Range +/-	50 km
Max gradient	20%	Max gradient	20%
Dimensions	3350x1220x1965 mm	Dimensions	3350x1220x1965 mm
Wheelbase	2460 mm	Wheelbase	2460 mm
Battery	No Battery incl.	Battery	No Battery incl.
Charge unit	17A	Charge unit	17A
Engine	6kW	Engine	6kW
Controller	Curtis	Controller	Curtis
Optional	Plastic cargobox Open Alu Box 1000x1100x400 mm Rear Seat with extended roof Lead acid 48V 165Ah or 220Ah LiFePO4 (Lithium) 48V 106Ah or 48V 173Ah 10kW motor Off-Road Package	Optional	Plastic cargobox Open Alu Box 1000x1100x400 mm Rear Seat with extended roof Lead acid 48V 165Ah or 220Ah LiFePO4 (Lithium) 48V 106Ah or 48V 173Ah 10kW motor Off-Road Package

### eFFort eS-WSL (Street Legal)

Category	L7eCP
Curb weight	502 kg
Max total mass	734 kg
Max speed	35 km/h
Range +/-	50 km
Max gradient	25%
Dimensions	2840x1305x1950 mm
Wheelbase	1870mm
Battery	LiFePO4 (Lithium) 48V 160Ah
Charge unit	25A
Engine	6.3kW
Controller	Curtis
Standard	Open Alu Box 1100x1000x270 mm

### Pilotcar PC-WSL (Street Legal)

Category	L7eCP	Category	L7eCP
Curb weight	(LA)660 - (LIT) 551 kg	Curb weight	(LA)660 - (LIT) 551 kg
Total load cap	485 kg	Total load cap	485 kg
Max speed	50 km/h	Max speed	50 km/h
Range +/-	50 km	Range +/-	50 km
Max gradient	20%	Max gradient	20%
Dimensions	3640x1220x1950 mm	Dimensions	3640x1220x1950 mm
Wheelbase	2500 mm	Wheelbase	2500 mm
Battery	No Battery incl.	Battery	No Battery incl.
Charge unit	17A	Charge unit	17A
Engine	6kW	Engine	6kW
Controller	Curtis	Controller	Curtis
Optional	Plastic cargobox Open Alu Box 1800x1300x400 mmf Lead acid 48V 165Ah or 220Ah LiFePO4 (Lithium) 48V 106Ah or 48V 173Ah 10kW motor Off-Road Package	Optional	Plastic cargobox Open Alu Box 1800x1300x400 mmf Lead acid 48V 165Ah or 220Ah LiFePO4 (Lithium) 48V 106Ah or 48V 173Ah 10kW motor Off-Road Package

# What is Street Legal?



A Street Legal vehicle in our range complies with **European directives** according to type approval under the category L6 or L7 low-speed vehicles.

SL-vehicles are offered with a COC document as standard according to EU homologation legislation, allowing the customer to apply for a registration plate. A windscreen with wiper, light package, three-point seatbelt, ... are standard.

Furthermore, a street legal vehicle is always provided with a Chassis number, a non street legal vehicle is provided with a Serial number.

Security glass windshield with windshield wiper and wash system



Premium seats with adjustable headrest & mandatory three-point safety belt



Full halogen lighting package with LED daylights



Four wheel hydraulic braking system with electronic handbrake



EU COC document with type approval L6 or L7 - CP or CU



Full cabin with heating and air conditioning



Digital display integrated in dashboard





# What & Where?

In certain models we offer variations based on customers needs and demands.

The eS2 and eS2Golf are examples of such variations. Both golf carts are for two people and are not suitable for public roads; in other words, neither can be licensed with a number plate. However, there are differences between these two models.

The appearance and design are completely different, so we offer a choice. A car has also different models with different designs and packages. Performance also varies in different motors, controllers, and battery packs.

For example, golf courses with larger numbers will opt for the eS2Golf because they can embroider the logo on the seat and the cart is easy and less expensive. This doesn't mean that one model is better than the other.

## eFFort eS-2Golf (Not Street Legal)

Category	Not Street Legal
Curb weight	560 kg
Max speed	25 km/h
Range +/-	50 km
Max gradient	30%
Dimensions	2740x1210x1820 mm
Wheelbase	1670 mm
Battery	LiFePO4 (Lithium) 48V 105h
Charge unit	25A
Engine	4kW
Controller	From factory



## eFFort eS-2 (Not Street Legal)

Category	Not Street Legal
Curb weight	360 kg
Max speed	30 km/h
Range +/-	70 km
Max gradient	30%
Dimensions	2380x1200x1850 mm
Wheelbase	1650 mm
Battery	LiFePO4 (Lithium) 48V 160h
Charge unit	25A
Engine	6.3kW
Controller	Curtis



- Preference for design**
- Special color or custom logo**
- Difference between motor and controller**
- Difference in battery capacity**
- Windshield with wiper**
- Application - tires**
- Stock**

# Possibilities?

For some applications and for some customers, there are numerous options.

Below, we give some available options alongside a utility vehicle type eS-W. It's important to understand the customer's needs, in what price range we offer, what's important to the customer, the expected delivery time, so you can make a selection from the various 'cargo' vehicles.

## eFFort eS-W (Not Street Legal)

Category	Not Street Legal
Curb weight	440 kg
Loading capacity	500 kg
Max speed	30 km/h
Range +/-	50 km
Max gradient	30%
Dimensions	3330x1200x1830 mm
Wheelbase	2450 mm
Battery	LiFePO4 (Lithium) 48V 160h
Charge unit	25A
Engine	6.3kW
Controller	Curtis
Cargobox	1650x1100x275mm
Tipper	Electric



- eFFort eS-2 with cargobox**
- Pilotcar PC-2 with cargobox**
- Pilotcar PC-W**
- eFFort eS-WSL**
- Pilotcar PC-WSL**
- eFFort eS-2UTVSL**
- eFFort CargoTruck**
- eFFort MiniCargo**
- eFFort e-Trike**
- Used Club Car with cargobox**



# VEHICLES - NON STREET LEGAL

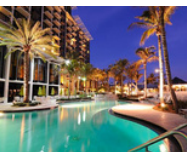

Amusement park

Camping

Factory premises

Golf

Zoo

Private terrains

Hotels & Resorts



PC2

- 2-seater (+2 or cargo optional)
- 6kW engine
- 40 km/h
- 100% electric
- 50 km autonomy\*
- Off-road / lifted version
- All options available, not mandatory
- Battery not included



PC4

- 4-seater (+2 or cargo optional)
- 6kW engine (10kW optional)
- 45 km/h
- 100% electric
- 50 km autonomy\*
- Off-road / lifted version
- All options available, not mandatory
- Battery not included



PCW

- 2-seater utility
- 6kW engine (10kW optional)
- 35 km/h
- 100% electric
- 50 km autonomy\*
- Off-road / lifted version
- 800kg load cap / 1500kg tow cap
- Open cargo: 180x130x40
- All options available, not mandatory
- Battery not included

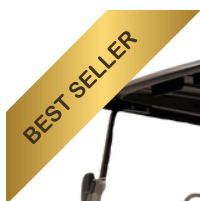
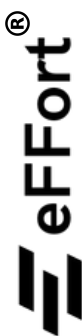

eS-2 GOLF (Not Street Legal)

- 2-seater (+2 or cargo optional)
- 4kW engine
- 30 km/h
- 100% electric
- 50 km autonomy\*
- All options available, not mandatory
- Battery included (LiFePO4 eFFort)



eS-4

- 4-seater (+2 or cargo optional)
- 6kW engine
- 40 km/h
- 100% electric
- 50 km autonomy\*
- All options available, not mandatory
- Lithium battery included



eS-W

- 2-seater utility
- 6kW engine
- 35 km/h
- 100% electric
- 50 km autonomy\*
- 350kg load capacity
- Open Cargo: 165x110x27
- All options available, not mandatory
- Lithium battery included



Plug & Play

70x110x27

EU168/2013\*

# VEHICLES - NON STREET LEGAL



## PC6

- 6 seater (Optional +2)
- 6kW engine (10kW optional)
- 35 km/h
- 100% electric
- 50km autonomy
- All options available, not mandatory
- Battery not included



## PCH

- Wheelchair ramp
- 4 seater (+ 2 Optional)
- 6kW engine (10kW optional)
- 35 km/h
- 100% electric
- 50km autonomy\*
- All options available, not mandatory
- Battery not included



## PCA

- Ambulance
- 2 seater
- 6kW engine (10kW optional)
- 30 km/h
- 100% electric
- 50km autonomy\*
- All options available, not mandatory
- Battery not included

## Options

EU168/2013\*



Rear Seat



Extended Suntop



Alu Box PC (100x110x40)  
Alu Box ES (70x110x27)



Plastic Box



Standard LED light



Foldable Windshield



Standard Golf Seat



Towing Hitch



Lifted / Off-road



Bull Bar



Mesh Box PCW  
(180x130x130)



Closed Box PCW  
(175x124x130)



# Differences Pilotcar & eFFort

With eSupplier, we aim to be a multi-brand organisation where we can respond to each customer's demand.

Every customer has their demands, needs and requirements related to the purchase or rental of a low-speed electric vehicle. As eSupplier we play an advisory role and look at the application, budget, needs, desires, ... to make a perfect fit between our customers and the vehicles.

We offer several types in the same range because at the end, the choice always lies with the customer, he chooses what he buys & where he buys it.

Our brands are supported with a large stock of spare parts, technical support and service from Belgium.

## Pricing

Every customer has a different budget. With eSupplier, we offer different options in different price ranges within the same product range. Our highest priority, with all our brands, is our critical look for high quality! We guarantee parts, service and look forward to a long-term cooperation!

## Application

Every application requires a different vehicle. After years of experience in low-speed electric vehicles, we are happy to share with you our opinion. We look at suspension, motor capacity, chassis, battery and are happy to answer all technical questions.



## Specials

For larger projects, the eFFort range allows us to be more customer oriented. All vehicles can be customised such as different RAL colour, different types of seats, embroidered logo in colour in the seat, body, motor, lighting, ...

## Stock

If you need your golf cart quickly, we will check what is available in stock from Belgium. Keep in mind that we have +/- 100 different vehicles in stock, ready to deliver.

We will find a fit for everyone at short notice.



# eFFort - UTV 4x4



Meet our Electric eFFort UTV – compact, robust, and built to perform. Equipped with two electric motors, this 4x4 delivers maximum traction and control on any surface.

With a high-capacity lithium battery, hydraulic braking system, digital display, windscreen, and wiper, it's fully equipped for everyday use. Easily switch between 2WD and 4WD to conquer any terrain – from muddy tracks to steep slopes.

Optional features include a winch, fully enclosed cabin (doors and windows), tow hitch, EPS power steering, and much more.

Top performance, top features, unbeatable price!

The ideal electric UTV for municipalities, agriculture, rental, industry, or recreational use.



- ✓ 2 Seater - Street Legal      Lithium Battery 11.04 kWh ✓
- ✓ 4 Seater - Not Street Legal      2WD/4WD switch ✓
- ✓ Top Speed up to 55km/h      Towing up to 500kg ✓



## Street legal?

The eFFort 2 seater UTV is homologated for the public road. This vehicle is category L7e and had a loading cap up to 185kg. The eS-4 UTV can only operate on private property and does not have the EU approval for public roads.

### eFFort eS-2UTVSL (Street Legal)

Category	L7eCP
Curb weight	788 kg
Loading capacity	185kg
Towing capacity	500kg
Max speed	55 km/h
Range +/-	50 km
Max gradient	30%
Dimensions	2950x1430x1780 mm
Wheelbase	1905 mm
Battery	LiFePO4 (Lithium) 72V 150Ah
Charge unit	25A
Engine	10kW (3/7)
Cargobox	1180x930x340mm
EPS	Included
Optional	Full Cabin

### eFFort eS-4UTV (Not Street legal)

Not Street Legal	Category
950 kg	Curb weight
185 kg	Loading capacity
500 kg	Towing capacity
55 km/h	Max speed
50 km	Range +/-
30%	Max gradient
3695x1495x1890 mm	Dimensions
2710 mm	Wheelbase
LiFePO4 (Lithium) 72V 150Ah	Battery
25A	Charge unit
10kW (3/7)	Engine
1180x930x340mm	Cargobox
Included	EPS
Optional	Full Cabin
Optional	Optional



# SHUTTLEBUS - NON STREET LEGAL



Compact, powerful, and comfortable — our electric shuttle bus is the perfect solution for sustainable passenger transport.

Equipped with a high-capacity lithium battery for maximum range, power steering for effortless control, and a digital display keeping all functions at your fingertips.

The shuttlebus is standard with hydraulic braking system, radio, seatbelts, lots of storage room, windshield with wiper and countless other stuff.

Available in configurations for 8 to 17 passengers, fully customizable to your needs:

- Optional fully enclosed cabin with doors and windows, or a plastic enclosure for our open cabin
- Optional heating system and other comfort features

## Pricing

Our electric shuttle bus combines innovation, comfort, and performance at a remarkably affordable price. With eSupplier, we work with fixed partners and look for the import, customs clearance, assembly, aftersales, ... for the range of shuttle buses in order to give you our best possible price.

## Performance

After years of experience in our own rental fleet and a good flow in parts and service, we know what the customer needs.

With a 72V 315Ah Lithium battery, built-in charger, 7.5kW to 11kW motor, EPS, ... provided as standard, we are always going to deliver a high quality bus.

## Tailor-made

In our range of shuttles, we work with you on different seats, logos and body looks. Furthermore, the bus can be open, closed (half- or full-glass doors) or with a flexible enclosure. Ultimately, you can use the bus to create a fully customised package.



### eFFort eS-11 (Open - Closed)

Category	Not Street Legal
People	11 people
Curb weight	1170 kg
Max speed	30 km/h
Range +/-	80 km
Max gradient	15%
Dimensions	4185x1510x2040 mm
Wheelbase	1885 mm
Battery	LiFePO4 (Lithium) 72V 230Ah
Charge unit	25A
Engine	7.5kW
Optional	Open or Closed Version LiFePO4 72V 280Ah

### eFFort eS-14 (Open - Closed)

Category	Not Street Legal
People	14 people
Curb weight	1300 kg
Max speed	30 km/h
Range +/-	80 km
Max gradient	15%
Dimensions	4970x1510x2040 mm
Wheelbase	2670 mm
Battery	LiFePO4 (Lithium) 72V 230Ah
Charge unit	25A
Engine	7.5kW
Optional	Open or Closed Version LiFePO4 72V 280Ah



# CARGO - STREET LEGAL



A fully electric vehicle equipped with everything you need as standard. Spacious, agile and surprisingly affordable. No endless list of expensive options - just well taken care of. As you would expect from eSupplier, as we know how electric driving really works. The eFFort Cargo-Truck is the answer to today's uncertainty and an investment in tomorrow's sustainability. For entrepreneurs who want to move forward, without fuss. Because you deliver every day. Because we do too. Our eFFort Cargo-Truck is ready for what is coming!



## Cabin

The materials in the eFFort are of high quality. The seats and dashboard are durable and made of aesthetic materials for optimal comfort. Moreover, it is standard with a touchscreen system with Bluetooth functionality.

The cabin of the eFFort offers unparalleled comfort due to its exceptional width, making it the most comfortable in the market. The spacious layout allows drivers and passengers to enjoy extra freedom of movement and an enhanced driving experience.

The ergonomically designed seats ensure that even long journeys are pleasant and relaxing.

## Battery

The eFFort offers the perfect solution for every challenge, thanks to its all-electric drive, compact measurement and impressive range. The vehicle features a 23kWh Lithium battery that is maintenance-free, offers a range of up to 200km and can handle 'fast charging'.

**EU homologation - Street Legal** ✓

**Range up to 200 km** ✓

**Top Speed up to 75km/h** ✓

**5-7h Charge** ✓

**Up to 600kg loading capacity** ✓



## Price

The eFFort Cargotruck has very competitive pricing and great value for money! You will nowhere find a more interesting offer! Contact us to learn more about this top-class vehicle. You are more than happy to book a demo ride at our premises or invites during one of our many eSupplier-on-Tour trips to showcase the vehicle on site!



## SIMPLICITY

1. LCD HD color display
2. USB port connection
3. Power steering wheel
4. Air conditioning
5. Storage compartments
6. Acoustic Vehicle Alerting System
7. Electric windows
8. START/STOP button
9. Central locking system
10. Contactless key

# CARGO - STREET LEGAL

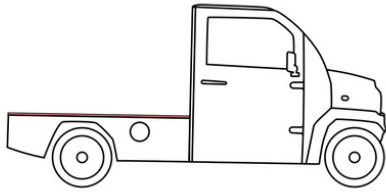

## eS-Cargo / Flat Bed

- Chassis version
- 10kW engine
- 75 km/h
- 100% electric

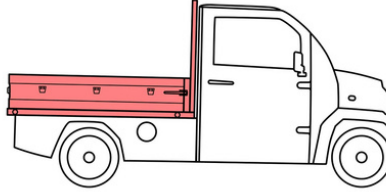

## eS-Cargo / Pick-up

- Open Cargo Box version
- 10kW engine
- 75 km/h
- 100% electric

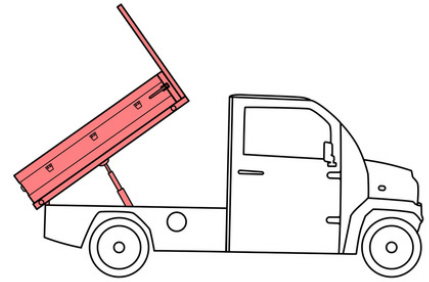

## eS-Cargo / Tipper

- Open Cargo Box with tipper version
- 10kW engine
- 75 km/h
- 100% electric

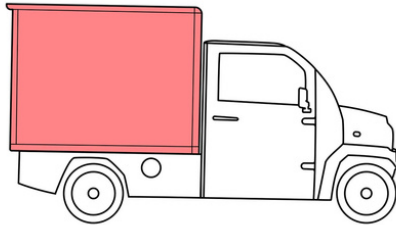

## eS-Cargo / Closed

- Closed Cargo Box (no side doors)
- 10kW engine
- 75 km/h
- 100% electric

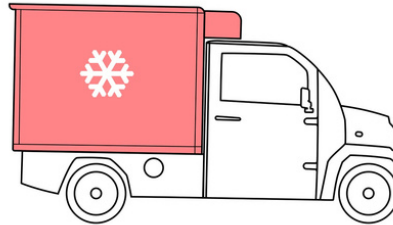

## eS-Cargo / Closed Cold

- Closed Cargo Box (no side doors)
- 10kW engine
- 75 km/h
- 100% electric

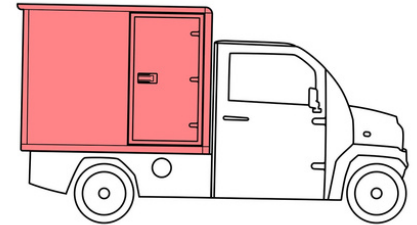

## eS-Cargo / Closed Door

- Closed Cargo Box (one side doors)
- 10kW engine
- 75 km/h
- 100% electric

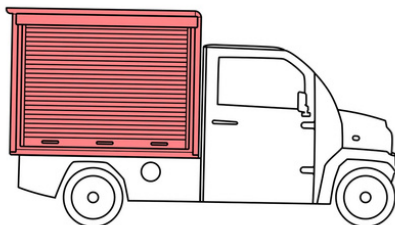

## eS-Cargo / Closed Roll-up

- Closed Cargo Box (Full side roller door)
- 10kW engine
- 75 km/h
- 100% electric

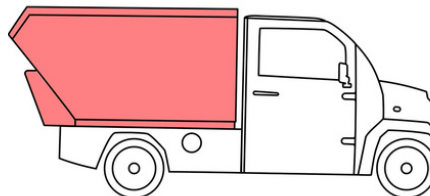

## eS-Cargo / Waste Collection

- Waste Collection (CUSTOM)
- 10kW engine
- 75 km/h
- 100% electric

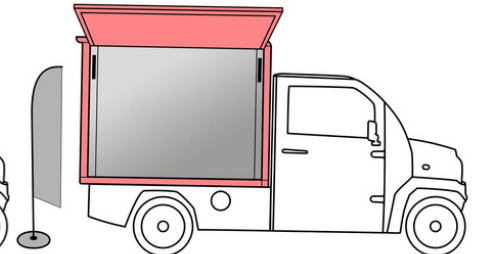

## eS-Cargo / Display

- Display - Marketing (CUSTOM)
- 10kW engine
- 75 km/h
- 100% electric



# CARGO - VEHICLE DIMENSIONS

## Dimensions Closed & Cold

<b>A</b> Length	3700 mm	<b>D</b> Wheelbase	2500 mm
<b>B</b> Width	1440 mm	<b>E</b> Ground Clearance	160 mm
Width (incl. Mirror)	1735 mm	<b>F</b> Cargo Bed Height	700 mm
<b>C</b> Height	2100 mm		

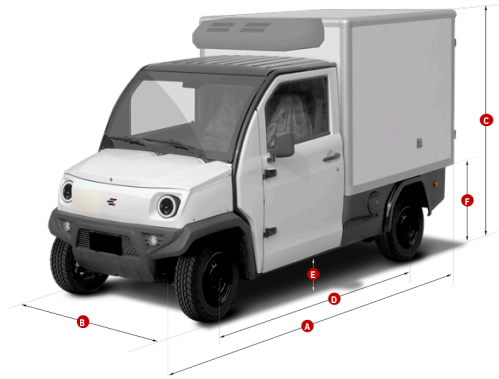
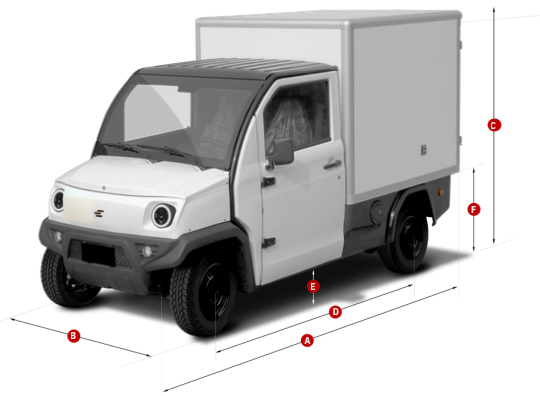

## Dimensions Pick-Up & Tipper

<b>A</b> Length	3700 mm	<b>D</b> Wheelbase	2500 mm
<b>B</b> Width	1440 mm	<b>E</b> Ground Clearance	160 mm
Width (incl. Mirror)	1735 mm	<b>F</b> Cargo Bed Height	700 mm
<b>C</b> Height	1800 mm		

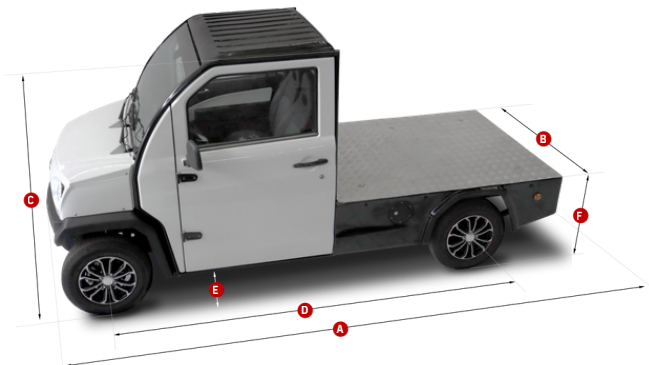
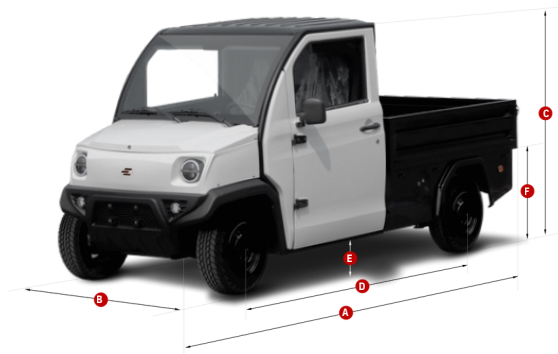

## Dimensions Flat

<b>A</b> Length	3600 mm
<b>B</b> Width	1440 mm
<b>B</b> Width (incl. Mirror)	1735 mm
<b>C</b> Height	1750 mm
<b>D</b> Wheelbase	2500 mm
<b>E</b> Ground Clearance	160 mm
<b>F</b> Cargo Bed Height	700 mm

# CARGO - BOX DIMENSIONS

## CLOSED CARGO BOX

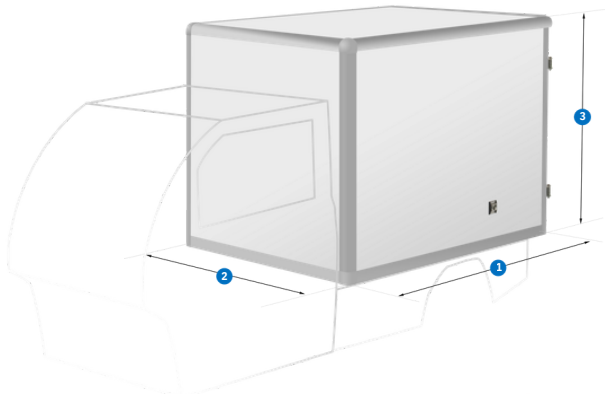

① Length Outside	1710 mm
① Length Inside	1635 mm
② Width Outside	1450 mm
② Width Inside	1420 mm
③ Height Outside	1360 mm
③ Height Inside	1290 mm

## CLOSED COLD CARGO BOX

① Chiller unit	540 mm
① Length Outside	1710/2260 mm
① Length Inside	1625 mm
② Width Outside	1450 mm
② Width Inside	1365 mm
③ Height Outside	1360 mm
③ Height Inside	1275 mm
Compressor rated power	700 W (72V)
① Service temperature	-18 ~+10°C

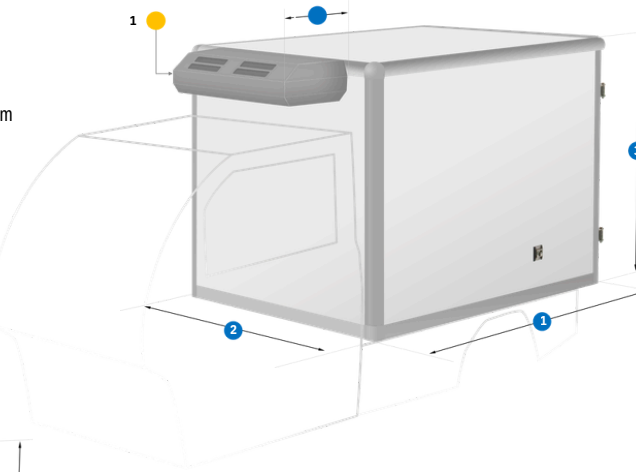

## PICK UP CARGO BOX

① Length Outside	1700 mm
① Length Inside	1660 mm
② Width Outside	1375 mm
② Width Inside	1335 mm
③ Height	1100 mm
④ Total Height	325 mm
⑤ Height Headboard	775 mm



## PICK UP TIPPER CARGO BOX

① Length Outside	1742 mm
① Length Inside	1627 mm
② Width Outside	1440 mm
② Width Inside	1300 mm
③ Height	1075 mm
④ Total Height	325 mm
⑤ Height Headboard	730 mm
Payload Area	2.2 m <sup>2</sup>
Max Height Tray Raised	2630 mm
Max Tipping Angle Tray	45°
Lifting time (empty)	15 sec

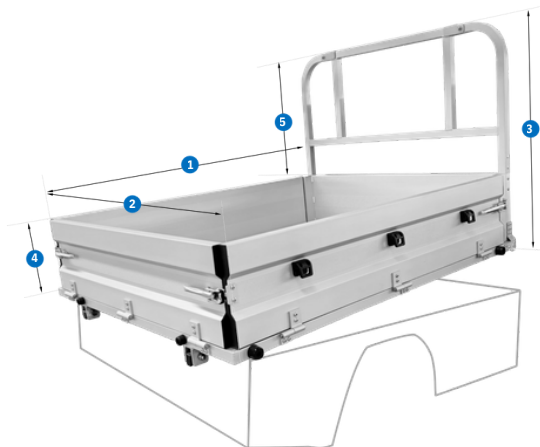

# CARGO - SPECIFICATIONS



LEGENDARY PERFORMANCES,  
**EXCEPTIONAL COMFORT**

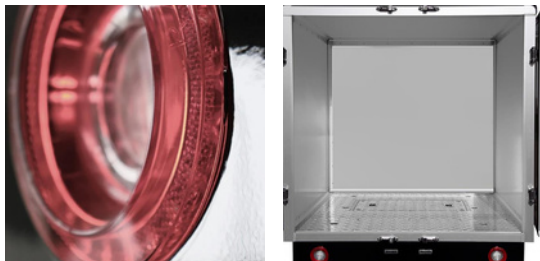

## SPECSHEET

### GENERAL

Gross vehicle weight (kg)	1450
Curb weight (kg)	845
Max. load capacity (kg)	600
Max. speed (km/h)	75
Max. gradient	25%
Min. turning circle (m)	5,5
Range in practice (km)	200
Vehicle warranty	2 years or 50.000km

### BATTERY

Battery Type	LiFePO4
Rated Capacity (Ah/kWh)	300Ah / 23
Nominal Voltage (V)	76,8

### LOADING SYSTEM

On-board charger (kW)	3,3
Type of connector	EU Type 2
Charge time 20-80% (h)	4
Charge time 0-100% (h)	7

### ELECTRIC DRIVE

Engine type	Permanent Magnet Synch. Engine (PMSM)
Cooling	Air-cooled
Drive	Rear-wheel drive
Electric motor power	10kW / 20kW peak
Maximum torque (Nm)	112
Transmission	Automatic

### CHASSIS

Suspension	McPherson (independent suspension)
Brake system Front	Brake discs
Brake system Rear	Drum brakes
Tyre size	155/65 R13

### STANDARD

- OBC 3.3kW
- 2 reclining seats
- Faux leather seats
- Metal door and cabin
- Adjustable headrests
- Three-point seat belts
- LED lights
- Seat belt warning
- Doors warning
- Central door lock
- Remote control key
- Electric windows
- Electric heating
- Reversing camera
- 9" touch-screen multimedia system
- Radio
- Air conditioning

### SAFETY

- ABS (Anti-Lock Braking System)
- EPS (Electronic Power Steering)
- PAS (Pedestrian Alert Systems)
- Regen Brakingsystem
- BOS (Brake Override System)

### OPTIONAL

- Custom made box (with racks)
- Towing hook
- Wall Charger 7.4kW
- Battery 150Ah / 11,50kWh
- Warning triangle
- Blue Spot / Amber Flashing Light

# VEHICLES - SPECIALS



Last mile delivery



Camping



Amusement park



Municipalities



Sports sites



Hospitals



## Mini-Cargo

- 1 or 2 seater
- 7.5kW engine
- 45 km/h
- 100% electric
- 130km autonomy\*
- 200kg load cap
- Full option
- Battery included (11.5kWh Lithium)



## Cargo e-Trike

- 1 seater
- 3kW engine
- 45 km/h
- 100% electric
- 75km autonomy\*
- 300kg load cap
- Full option
- Battery included (6.4kWh Lithium)

EU168/2013\*

Our eFFort **Mini-Cargo** is the smaller version of our eFFort Cargo-Truck. Unlike the Cargo-Truck, the Mini is often designed for one driver. With almost all the same features as the Cargo-Truck this smaller eFFort vehicle offers a very high level of driving comfort. Our vehicle is allowed for public roads (L7) and has a speed up to 45 km/h. The cargo makes it a perfect fit for small deliveries, small trips in city centers, campings or at sport & music events.

Our eFFort **E-Trike** is a cargo three-wheel truck for small deliveries or advertising. It is a compact and well-built vehicle that can be used for many different applications. It features a cargobox (110 x 100 x 100 cm) with a load capacity of 400 kg. This beautiful electric vehicle, available in L5 category, will definitely stand out in the streets!

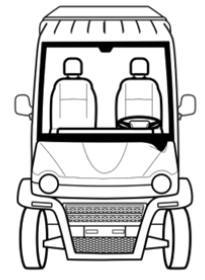

Different seat position options (LHD or Middle)

Standard closed or open cargo box available



Full halogen lighting package with LED daylights



Digital screen with bluetooth functionality



# MINI CARGO - STREET LEGAL

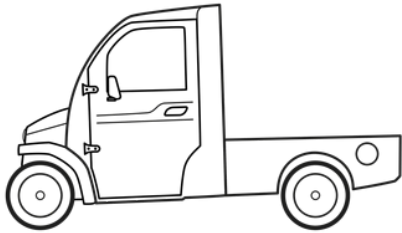

**eS-MiniCargo / Flat Bed**

- Chassis version
- 7.5kW engine
- 45 km/h
- 100% electric

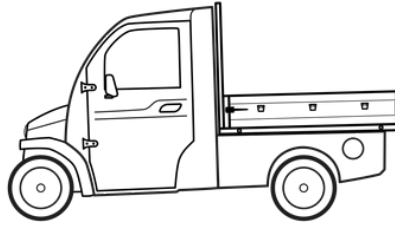

**eS-MiniCargo / Pick-up**

- Open Cargo Box version
- 7.5kW engine
- 45 km/h
- 100% electric

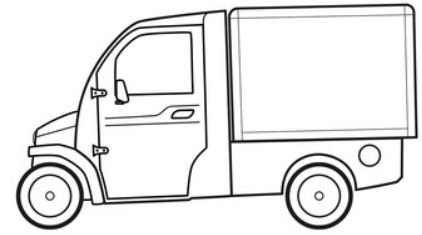

**eS-MiniCargo / Closed**

- Closed Cargo Box (no side doors)
- 7.5kW engine
- 45 km/h
- 100% electric

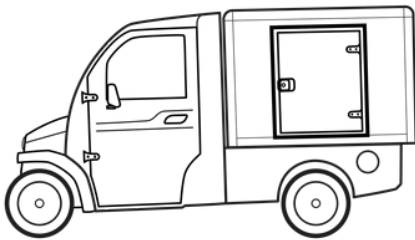

**eS-MiniCargo / Closed Door**

- Closed Cargo Box (one side door)
- 7.5kW engine
- 45 km/h
- 100% electric

## Dimensions Closed

<b>A</b> Length	3175 mm	<b>F</b> Cargo Bed Height	680 mm
<b>B</b> Width	1240 mm	<b>G</b> Length box (out/in)	1250/1150 mm
Width (incl. Mirror)	1470 mm	<b>H</b> Width Box (out/in)	1200/1100 mm
<b>C</b> Height	1750 mm	<b>I</b> Height Box (out/in)	1000/950 mm
<b>D</b> Wheelbase	2090 mm		
<b>E</b> Ground Clearance	135 mm		

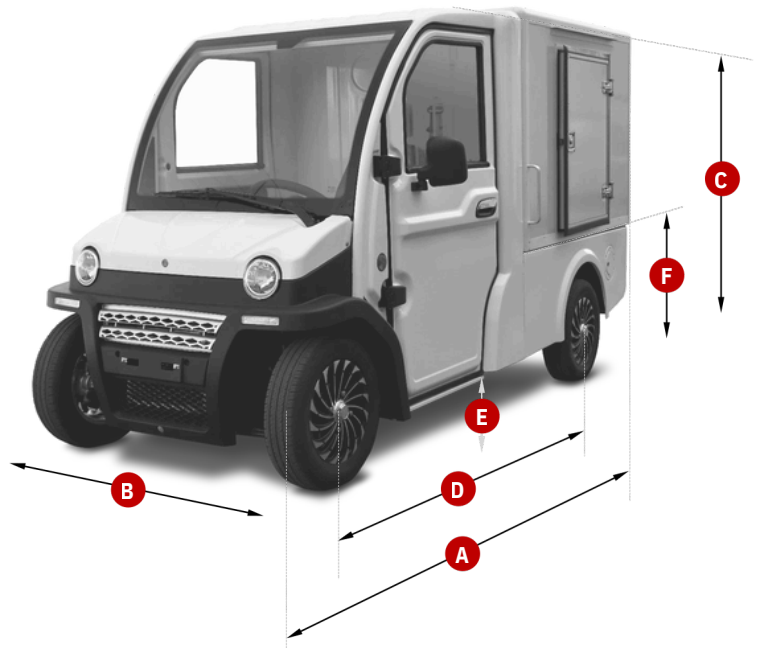
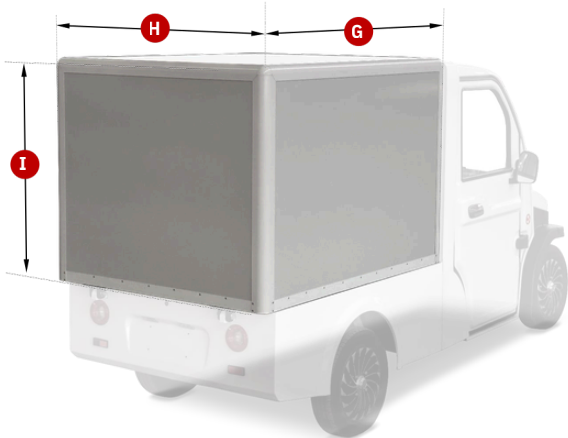

# MINI - SPECIFICATIONS



INCREDIBLE QUALITY,  
UNBELIEVABLE PRICE

## SPECSHEET

### GENERAL

Gross vehicle weight (kg)	1200
Curb weight (kg)	695
Max. load capacity (kg)	200
Max. speed (km/h)	45
Max. gradient	20%
Min. turning circle (m)	5
Range in practice (km)	100
Vehicle warranty	2 years or 50.000km

### BATTERY

Battery Type	LiFePO4
Rated Capacity (Ah/kWh)	150Ah / 11.5
Nominal Voltage (V)	76,8

### LOADING SYSTEM

On-board charger (kW)	2,2
Type of connector	EU Type 2
Charge time 20-80% (h)	4
Charge time 0-100% (h)	7

### ELECTRIC DRIVE

Engine type	Permanent Magnet Synch. Engine (PMSM)
Cooling	Air-cooled
Drive	Rear-wheel drive
Electric motor power	7.5kW / 15kW
Maximum torque (Nm)	85
Transmission	Automatic

### CHASSIS

Suspension	McPherson (independent suspension)
Brake system Front	Brake discs
Brake system Rear	Drum brakes
Tyre size	145/70R12 (LT)

### STANDARD

OBC 2.2kW  
1 or 2 seats  
Adjustable driver seat  
Full cabin  
Adjustable headrests  
Three-point seat belts  
Seat belt warning  
Doors warning  
Key in ignition  
Electric windows  
Electric heating  
Reversing camera  
Central door lock  
Multimedia system  
Radio

### SAFETY

ABS (Anti-Lock Braking System)  
BOS (Brake Override System)

### OPTIONAL

Custom made box (with racks)  
Towing hook  
OBC 6.6kW  
Warning triangle  
Blue Spot / Amber Flashing Light  
Air conditioning

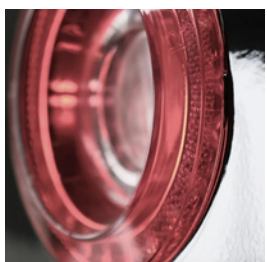
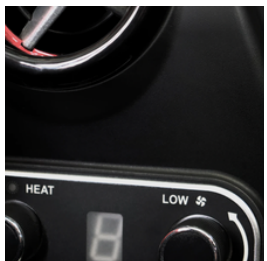

# ETRIKE - STREET LEGAL

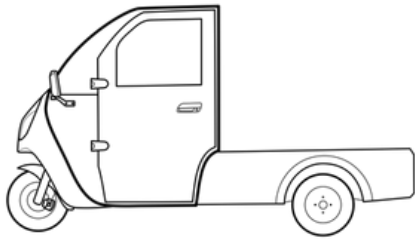

**eS-eTrike / Flat Bed**

- Chassis version
- 3kW engine
- 45 km/h
- 100% electric

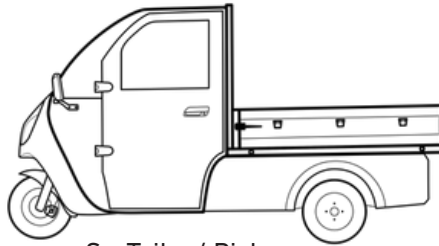

**eS-eTrike / Pick-up**

- Open Cargo Box version
- 3kW engine
- 45 km/h
- 100% electric

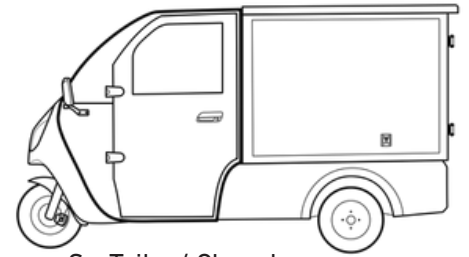

**eS-eTrike / Closed**

- Closed Cargo Box (no side doors)
- 3kW engine
- 45 km/h
- 100% electric

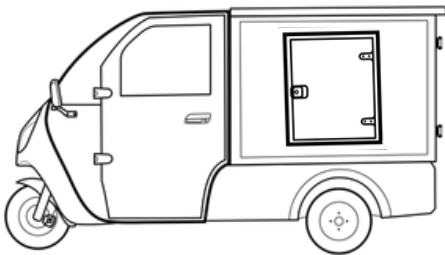

**eS-eTrike / Closed Door**

- Closed Cargo Box (one side door)
- 3kW engine
- 45 km/h
- 100% electric

## Dimensions Closed

<b>A</b> Length	2990 mm	<b>F</b> Cargo Bed Height	610 mm
<b>B</b> Width	1090 mm	<b>G</b> Length box (out/in)	1450/1335 mm
Width (incl. Mirror)	1075 mm	<b>H</b> Width Box (out/in)	1050/985 mm
<b>C</b> Height	1650 mm	<b>I</b> Height Box (out/in)	1050/995 mm
<b>D</b> Wheelbase	2100 mm		
<b>E</b> Ground Clearance	110 mm		

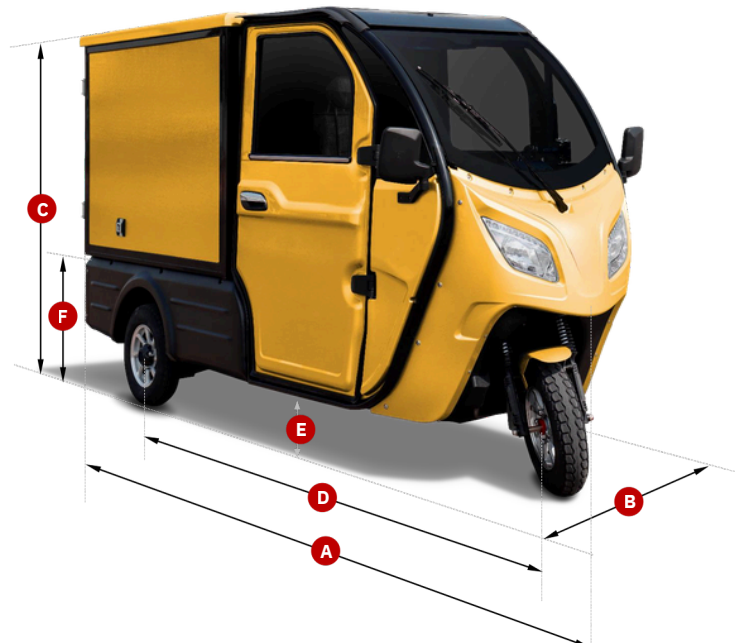
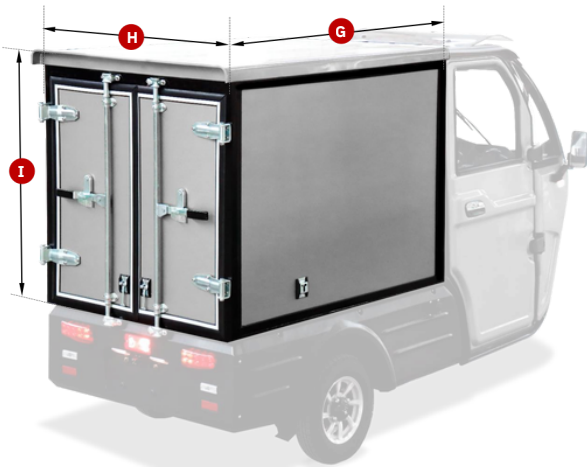

# ETRIKE - SPECIFICATIONS



INCREDIBLE QUALITY,  
**UNBELIEVABLE PRICE**

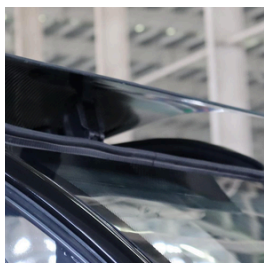
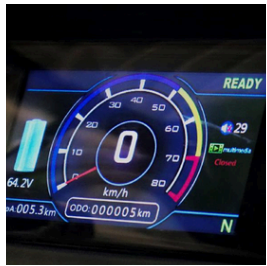

## SPECSHEET

### GENERAL

Gross vehicle weight (kg)	830
Curb weight (kg)	427
Max. load capacity (kg)	300
Max. speed (km/h)	45
Max. gradient	22%
Min. turning circle (m)	4.5
Range in practice (km)	50
Vehicle warranty	2 years or 20.000km

### BATTERY

Battery Type	LiFePO4
Rated Capacity (Ah/kWh)	100Ah / 6.0
Nominal Voltage (V)	60

### LOADING SYSTEM

On-board charger (kW)	1
Type of connector	GB/T
Charge time 20-80% (h)	4
Charge time 0-100% (h)	7

### ELECTRIC DRIVE

Engine type	Permanent Magnet Synch. Engine (PMSM)
Cooling	Air-cooled
Drive	Rear-wheel drive
Electric motor power	7.5kW / 15kW
Maximum torque (Nm)	85
Transmission	Automatic

### CHASSIS

Suspension	Front Shock Absorber Fork / Integral Suspension
Brake system Front	Brake discs
Brake system Rear	Drum brakes
Tyre size	120-90-10

### STANDARD

OBC 1kW  
CBS combined braking  
Adjustable driver seat  
Full cabin  
Three-point seat belts  
Key in ignition  
Electric windows  
Radio  
Reversing camera  
Central door lock  
Multimedia system  
Storage compartment  
Air vents

### OPTIONAL

Custom made box (with racks)  
Warning triangle  
Blue Spot / Amber Flashing Light

# eFFort LiFePO4 Batteries

## Belgian Design. Industrial Quality.

Experience longer run times, faster charging, and zero maintenance with our advanced LiFePO4 batteries. Designed for superior performance and reliability, these lightweight batteries deliver consistent power, extended life cycles, and smart energy management—making every ride smoother and more efficient.

With eSupplier we have dedicated our attention to build better batteries. Heavy Duty Applications like golfcarts, scissor lifts, cleaning machines and others require Heavy Duty Batteries. With a long history in lithium batteries and low speed vehicles, we continually implement new innovations.

### ✓ External Display

State of charge display is included in the package.

### ✓ External Button

The battery switches off automatically after standstill. With an external button you can reactivate it.

### ✓ EVE / S-Volt Cells

Our lithium battery is built with A-brand cells from EVE & S-Volt.

✓ The battery is **Serial Connected**, not parallel for less internal resistance, less complex construction, less cabling resulting in a smaller error rate.

### ✓ LFP Technology

The heart of the eFFort Battery is the LFP technology. Based on important parameters such as the highest score on safety & lifetime, you are getting a good battery for your application.

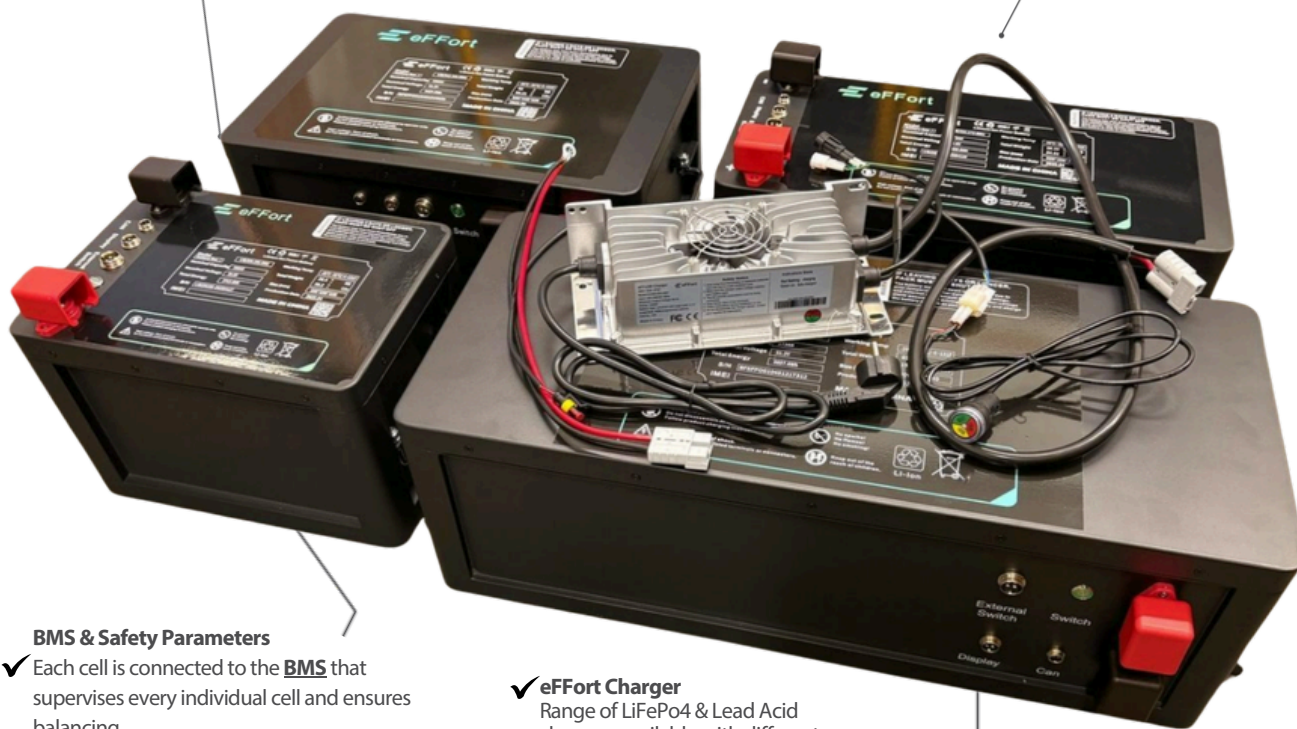

### BMS & Safety Parameters

- ✓ Each cell is connected to the **BMS** that supervises every individual cell and ensures balancing.
- ✓ **CAN Bus** communication is also implemented. The battery pack is provided on an individual cell base with **Temperature Sensors**.
- ✓ **High Peak Current**  
Providing high peak power for every application.

### ✓ eFFort Charger

Range of LiFePO4 & Lead Acid chargers available with different charging curves and multiple charging outputs (A).

### ✓ Open Design & Service

Service, diagnostics, spare parts and tailor-made follow-up from Belgium. Technical training is available too.

### ✓ Heating Mat

Integrated heating elements that perform when charging the battery. The heating element allows the battery to heat from -20°C to 0°C to start & charge. Discharging does not require a heating system and is possible between -20°C & 60°C.

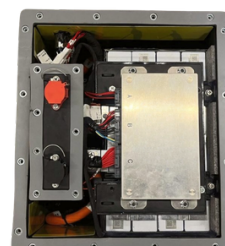
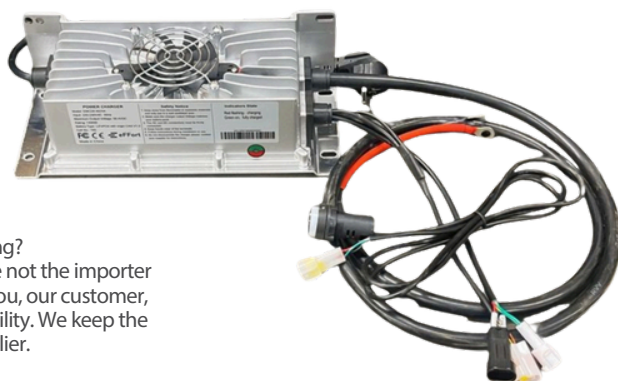

### ✓ European invoicing

Why European invoicing?  
We ensure that you are not the importer of the battery and so you, our customer, bear no final responsibility. We keep the responsibility at eSupplier.

# eFFort LiFePO4 Batteries

## Our eFFort, Your Equipment.

\*With terminal  
\*\*With terminal insulator  
\*\*\*With holddown

- 5 years or 3000 cycles warranty
- IP65 & IP67
- EU Certificates
- Maintenance Free
- High Peak Current
- Ultra-safe LFP Technology
- EU Invoice & Warranty
- Operations in Belgium

### • BMS APP



eFFort LiFePO4 Battery							
Ref. eSupplier	Voltage (V)	C20 (Ah)	Length (mm)	Width (mm)	Height (mm)	Weight (kg)	Kilowatt hours (kWh)
LIB/256.106.0001	25,60	106	350	250	230 *255 **280	25	2,72
LIB/256.173.0001	25,60	173	520	250	240 *270 **285	37	4,43
LIB/512.106.0001	51,20	106	500 ***580	330 *345 **360	220	48	5,43
LIB/512.173.0001	51,20	173	720 ***800	310 *325 **345	240	75	8,86



### Dimensions Charger

Ref. eSupplier	Length	Width	Height
CH/292.025.0001	29,2	24	25
CH/292.040.0001	29,2	24	40
CH/584.025.0001	58,4	48	25
CH/584.035.0001	58,4	48	35

### eFFort Charger

Ref. eSupplier	Output Voltage (V)	Nominal Voltage (V)	Amperage (A)	Rated voltage of battery pack (V)	Weight (kg)	Weight incl. box (kg)
CH/292.025.0001	29,2	24	25	25,6	2,18	3,6
CH/292.040.0001	29,2	24	40	25,6	3,5	5,0
CH/584.025.0001	58,4	48	25	51,20	2,6	3,6
CH/584.035.0001	58,4	48	35	51,20	3,8	4,9



# CROWN DEEP CYCLE BATTERIES

## Tough application, Tougher Batteries.

Crown Battery Manufacturing Company is a U.S.-based company that specializes in the design and production of high-quality, deep-cycle batteries. Founded in 1926 and headquartered in Fremont, Ohio, Crown Battery serves a variety of markets, including renewable energy, automotive, industrial, and commercial applications.

**PROeye™** – Clean and easy, our quick-look electrolyte level inspection system lets you know when it's time to add water.

### Rigid Connectors

Heavy-duty TTP, COS and Post connectors deliver maximum electrical efficiency and durability.

### PosiWrap™ Separators

Crown's proprietary PosiWrap Separators give you less to worry about and more to like by delivering improved charge acceptance, protection from short-circuiting and an even higher level of durability.

### SolidCast™ Plates

Our massive SolidCast Plates boast an advanced grid architecture and ultra-thick wires, with plates now holding more C-Force Active Mass than ever leading to highly efficient charging, longer discharge times and battery life, and extreme overall performance.

### Advanced Engineering

Intelligent, yet robust construction features industry-firsts such as our C-Force™ Active Mass and SolidCast™ plates which combine to accept charge more effectively, maintain it longer, and deliver on-demand power for your gear like nobody's business.



CR165



CR220



CR390

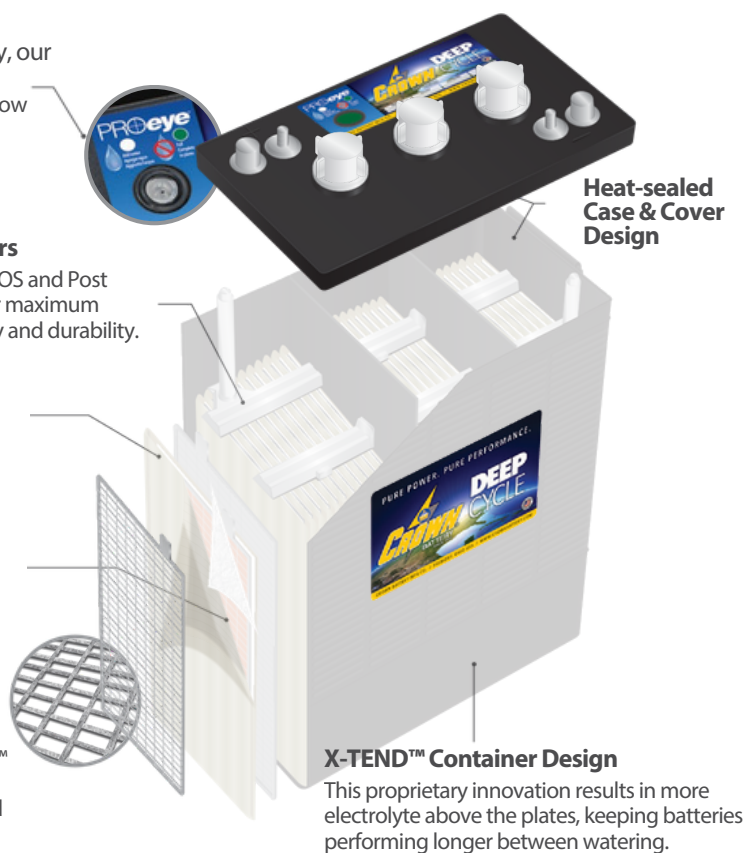

Ref.	Cross Ref.	Voltage (V)	C20 (Ah)	C5 (Ah)	Length (mm)	Width (mm)	Height (mm)	Weight (kg)	Layout	Terminals	Pallet
<b>6 Volt Deep Cycle Batteries</b>											
CRO/CR220HD	GC-220	6	220	180	260	179	278	27,8	6V: 1	DT 1 + 8	48
CRO/CR235HD	GC-235	6	235	190	260	179	278	29,0	6V: 1	DT 1 + 8	48
CRO/CR240E	DIN-240	6	240	195	245	191	273	31,0	6V: 1	1	48
CRO/CR260HD	GC2H-260	6	260	215	260	179	295	34,0	6V: 1	DT 1 + 8	48
CRO/CR250	J-250	6	250	200	298	183	283	33,0	6V: 1	DT 1 + 8	36
CRO/CR305HD	J-305	6	305	255	310	183	359	40,8	6V: 1	DT 1 + 8	24
CRO/CR330HD	J-330	6	330	270	310	183	359	42,0	6V: 1	DT 1 + 8	24
CRO/CR370HD	L16-370	6	370	295	314	183	410	46,0	6V: 1	DT 1 + 8	24
CRO/CR390HD	L16-390	6	390	310	314	183	410	52,2	6V: 1	DT 1 + 8	24
CRO/CR430HD	L16-430	6	430	340	314	183	410	55,3	6V: 1	DT 1 + 8	24
<b>8 Volt Deep Cycle Batteries</b>											
CRO/CR165	T165	8	165	140	262	179	275	29,0	1	S	48
<b>12 Volt Deep Cycle Batteries</b>											
CRO/24DC95	24DC	12	95	75	281	173	238	23,0	1	DT 1 + 8	64
CRO/27DC115	27DC	12	115	95	329	173	238	27,0	1	DT 1 + 8	48
CRO/31DC130	31DC	12	130	105	330	171	238	30,0	1	DT 1 + 8	48
CRO/GCCR150	GC12-150	12	150	123	328	179	267	37,0	1	DT 1 + 8	36

# PARTS & ACCESSORIES



**Rear Utility Steel Box Club Car**  
 • PA.02/SRRUSB-02

REQUEST A QUOTE



**Cargo Box Brackets Club Car**  
 • PA.02/CBMB-01

REQUEST A QUOTE



**Rear Seat Kit Club Car**  
 • PA.02/SRRSK-003

REQUEST A QUOTE



**Black Front Seat Club Car**  
 • PA.02/SRFS-009

REQUEST A QUOTE



**Golf cart 20x10-10 All Terrain**  
 • PA.02/SRGCT-14

REQUEST A QUOTE



**Alu Baggage Box Kit Pilotcar**  
 • PA.01/PCK0377

REQUEST A QUOTE



**Alu Baggage Mounting Assembly Kit Pilotcar**  
 • PA.01/PCK0379

REQUEST A QUOTE



**Foldable rear seat kit Pilotcar**  
 • PA.01/PCK0110-0002

REQUEST A QUOTE



**LED light kit Club Car**  
 • PA.02/SRLK-12

REQUEST A QUOTE



**6" A-Arm lift Kit Club Car**  
 • PA.02/SRLK3524-01-6inch

REQUEST A QUOTE

 English

## In-house Assembly in Belgium

Through our own in-house assembly, we provide large quantities of spare parts. With + 1000 references on our current brands, we ensure good after-sales for our network.

## Direct Purchase EU Parts

With direct lines to manufacturers such as Curtis & Schabmüller, we buy main parts directly from the manufacturers.

## Multi-Brand Spare Parts Stock

With an extensive stock, we can provide multiple brands with options such as rear seats, boxes, seats, ... On this page you can find a small selection of the possibilities.



# USED VEHICLES

## Fleet

At eSupplier, we specialise in large fleet purchases from major dealers and end customers internationally with our focus on renowned brands such as Club Car, Ez-Go & Yamaha. Therefore, we can offer more competitive prices in the market. International resales are mostly in FTL (Qty 10 - 11).



## Spare Parts

As mentioned the page before, we keep stock of spare parts for all the brands we offer. We also offer extra options for the golf carts at the most competitive price in the market in combination with fleet sales.



## Condition

The customer or reseller decides in which condition he wants to purchase the golf cart, this is possible in as-is, refurbished or technically inspected vehicle. We do ensure that vehicles are delivered in good working condition unless otherwise stated.



# OEM Battery Production

Our main focus is on prototyping, production & service for manufacturers and major importers. We are happy to help a manufacturer with starting up a new production line or assisting in the after-service for bicycles, motorcycles, electric wheelchairs, AGV's or any other application where lithium packs are used.

Many manufacturers are confronted with challenges in regard to ADR transportation, lead times, repairs & refurbishment, certification,... We can produce or refurbish large numbers and have all in-house knowledge of a LiFePO4 battery pack to quickly identify and solve the cause of a problem.

With our BatteryFix.pro department we have already served many manufacturers who have given us confidence as an independent party for their battery production and technical follow-up.

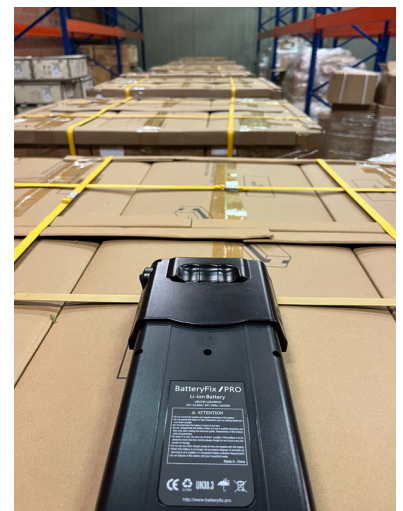

## Transport & storage

At BatteryFix, we invest heavily to relieve our customers in relation to the storage and transportation of lithium batteries. We store batteries in a secure approved environment and ship only what is needed and when it is needed.

## State-of-the-art prototypes

With our advanced design software and equipment, we quickly bring your battery ideas to life. Our specialists are happy to come on site to map everything such as the product/vehicle, dimensions for installation, removable battery, type of charger, required certifications or other specific needs.

## Quality production & certification

In our production department, we ensure that every battery we make meets the highest standards. Batteries can be ordered on demand or per order in small and large quantities.

We can also provide all the necessary certificates for your batteries so that you can install the batteries in your devices without any problems.

## Aftersales & service

We do in-house battery testing, repair, refurbishment and provide replacement batteries in case of unexpected problems. We are happy to serve many happy manufacturers in many different applications.

